

# HYDRAULIC MOTORS VMF

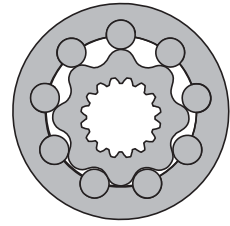

## APPLICATION

- » Marine equipment
- » Forestry equipment
- » Metal working machines
- » Agricultural machines
- » Road building machines
- » Mining machinery
- » Special vehicles etc.

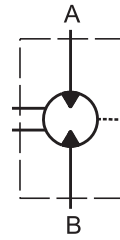

## CONTENTS

Specification data .....	45
Dimensions and mounting .....	46
Permissible shaft seal pressure.....	46
Permissible shaft loads .....	47
Order code .....	47

## OPTIONS

- » Model - Disc valve, roll-gerotor
- » Wheel mounting flange
- » Side ports
- » Shaft - thread hole flange
- » SAE and BSPP ports
- » Other special features

## GENERAL

<b>Max. Displacement,</b> cm <sup>3</sup> /rev [in <sup>3</sup> /rev]	801,8 [48.91]
<b>Max. Speed,</b> [RPM]	736
<b>Max. Torque,</b> daNm [lb-in]	cont.: 259 [22920] int.: 340 [30090]
<b>Max. Output,</b> kW [HP]	112 [150]
<b>Max. Pressure Drop,</b> bar [PSI]	cont.: 250 [3630] int.: 350 [5080]
<b>Max. Oil Flow,</b> lpm [GPM]	240 [63.4]
<b>Min. Speed,</b> [RPM]	5
<b>Permissible Shaft Loads,</b> daN [lbs]	Pa=1500 [3370]
<b>Pressure fluid</b>	Mineral based- HLP(DIN 51524) or HM(ISO 6743/4)
<b>Temperature range,</b> °C [°F]	-40÷140 [-40÷284]
<b>Optimal Viscosity range,</b> mm <sup>2</sup> /s [SUS]	20÷75 [98÷347]
<b>Filtration</b>	ISO code 20/16 (Min. recommended fluid filtration of 25 microns)

### Oil flow in drain line

Pressure drop bar [PSI]	Viscosity mm <sup>2</sup> /s [SUS]	Oil flow in drain line lpm [GPM]
140 [2030]	20 [98]	3 [.793]
	35 [164]	2 [.528]
210 [3045]	20 [98]	6 [1.585]
	35 [164]	4 [1.057]

### Pressure Losses

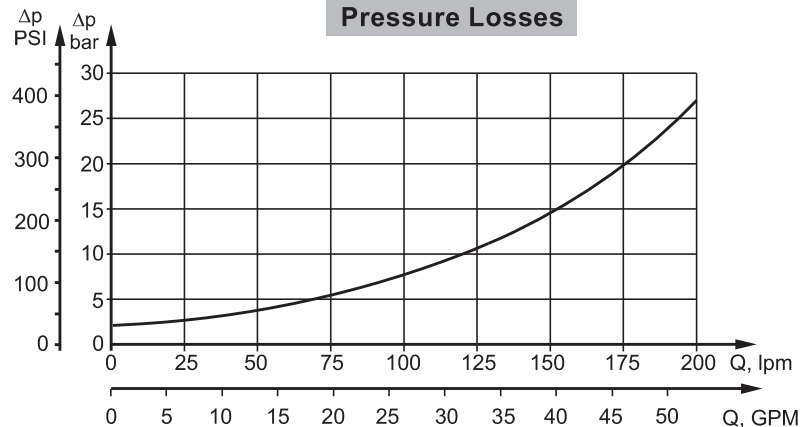

## SPECIFICATION DATA

Type	VMF 315	VMF 400	VMF 500	VMF 630	VMF 800	
<b>Displacement, cm<sup>3</sup>/rev [in<sup>3</sup>/rev]</b>	314,5 [19.18]	400,9 [24.5]	499,6 [30.5]	629,1 [38.38]	801,8 [48.91]	
<b>Max. Speed, [RPM]</b>	cont.	636	500	400	315	250
	Int.*	736	600	480	380	300
<b>Max. Torque daNm [lb-in]</b>	cont.	115 [10180]	144 [12745]	180 [15930]	227 [20090]	259 [22920]
	Int.*	160 [14160]	200 [17700]	260 [23010]	310 [27440]	340 [30090]
	peak**	180 [15930]	230 [20355]	286 [25315]	360 [31860]	402 [35580]
<b>Max. Output kW [HP]</b>	cont.	67 [90]	67 [90]	67 [90]	67 [90]	67 [90]
	int.*	112 [150]	112 [150]	112 [150]	112 [150]	112 [150]
<b>Max. Pressure Drop bar [PSI]</b>	cont.	250 [3630]	250 [3630]	250 [3630]	250 [3630]	225 [3263]
	Int.*	350 [5080]	350 [5080]	350 [5080]	350 [5080]	300 [4350]
	peak**	400 [5800]	400 [5800]	400 [5800]	400 [5800]	350 [5080]
<b>Max. Oil Flow lpm [GPM]</b>	cont.	200 [52.8]	200 [52.8]	200 [52.8]	200 [52.8]	200 [52.8]
	Int.*	240 [63.4]	240 [63.4]	240 [63.4]	240 [63.4]	240 [63.4]
<b>Max. Inlet Pressure bar [PSI]</b>	cont.	270 [3915]	270 [3915]	270 [3915]	270 [3915]	270 [3915]
	Int.*	370 [5365]	370 [5365]	370 [5365]	370 [5365]	370 [5365]
	peak**	420 [6090]	420 [6090]	420 [6090]	420 [6090]	420 [6090]
<b>Max. Return Pressure with Drain Line bar [PSI]</b>	cont.	140 [2030]	140 [2030]	140 [2030]	140 [2030]	140 [2030]
	Int.*	175 [2540]	175 [2540]	175 [2540]	175 [2540]	175 [2540]
	peak**	210 [3045]	210 [3045]	210 [3045]	210 [3045]	210 [3045]
<b>Max. Starting Pressure with Unloaded Shaft, bar [PSI]</b>	5 [70]	5 [70]	5 [70]	5 [70]	5 [70]	
<b>Min. Starting Torque daNm [lb-in]</b>	92 [8140]	115 [10180]	144 [12745]	180 [15930]	205 [18145]	
<b>Min. Speed***, [RPM]</b>	10	6	8	6	5	
<b>Weight, kg [lb]</b>	46 [101.4]	47,2 [104,1]	48,5 [106.9]	50 [110.2]	51,5 [113.5]	

\* Intermittent operation: the permissible values may occur for max. 10% of every minute.

\*\* Peak load: the permissible values may occur for max. 1% of every minute.

\*\*\* For speeds lower than given, consult factory or your regional manager.

1. Intermittent speed and intermittent pressure must not occur simultaneously.
2. Recommended filtration is per ISO cleanliness code 20/16. A nominal filtration of 25 micron or better.
3. Recommend using a premium quality, anti-wear type mineral based hydraulic oil HLP(DIN51524) or HM ( ISO 6743/4).  
If using synthetic fluids consult the factory for alternative seal materials.
4. Recommended minimum oil viscosity 13 mm<sup>2</sup>/s [70 SUS] at 50°C [122°F].
5. Recommended maximum system operating temperature is 82°C [180°F].
6. To assure optimum motor life fill with fluid prior to loading and run at moderate load and speed for 10-15 minutes.

**DIMENSIONS AND MOUNTING DATA**

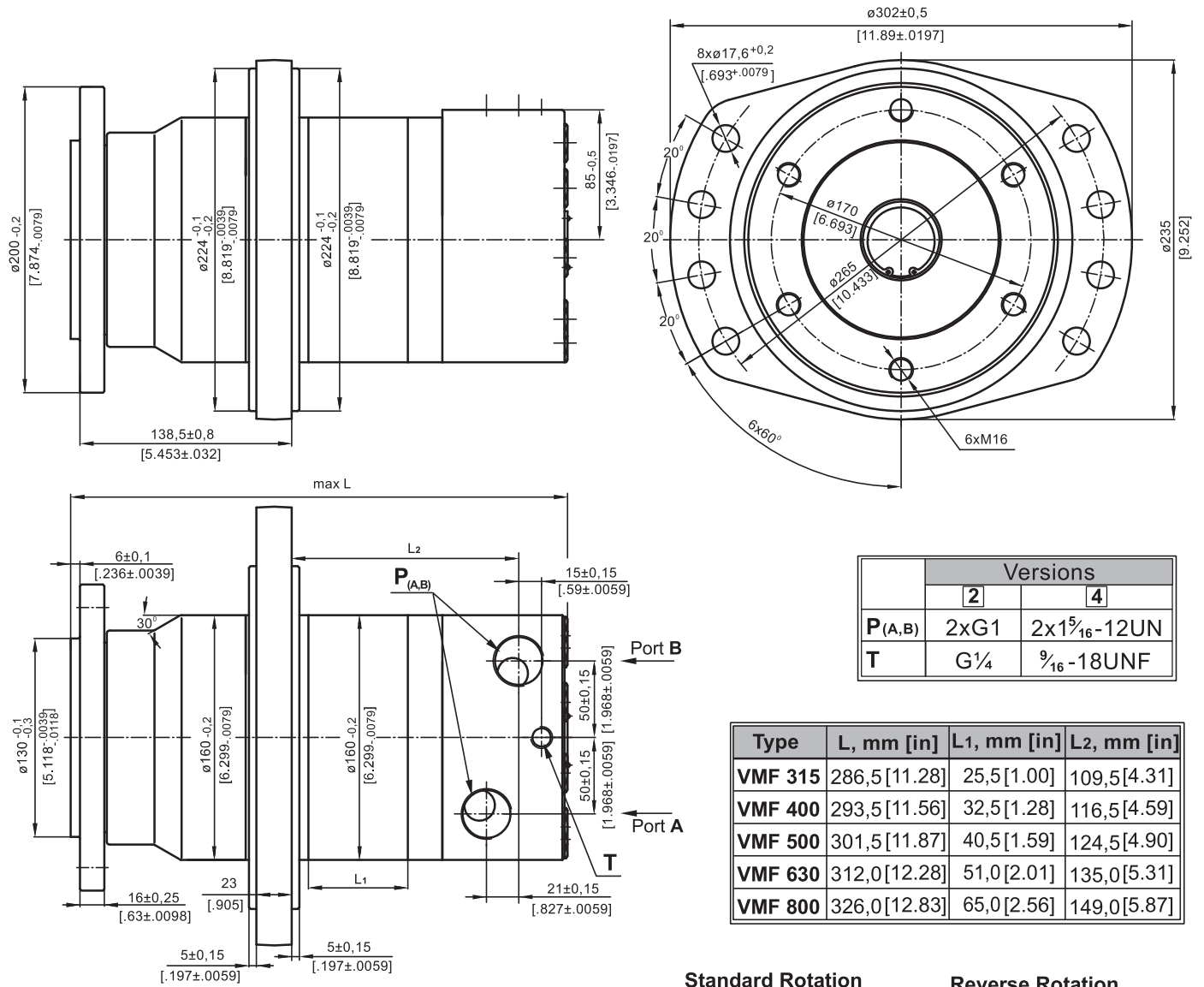

**Warning:** Drain line should always be used.

**Standard Rotation**  
Viewed from Shaft End  
Port A Pressurized - CW  
Port B Pressurized - CCW

**Reverse Rotation**  
Viewed from Shaft End  
Port A Pressurized - CCW  
Port B Pressurized - CW

**MAX. PERMISSIBLE SHAFT SEAL PRESSURE**

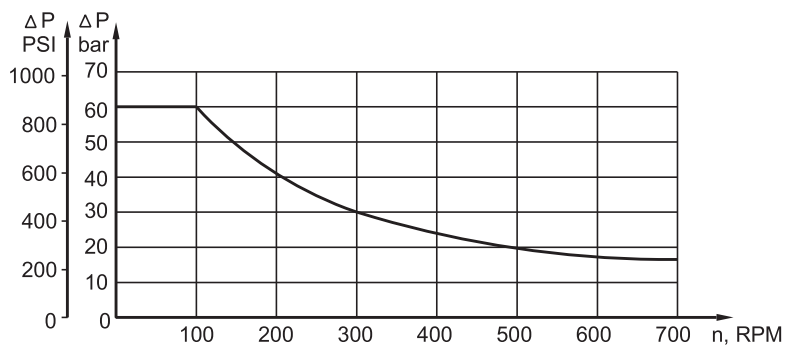

**PERMISSIBLE SHAFT LOADS**

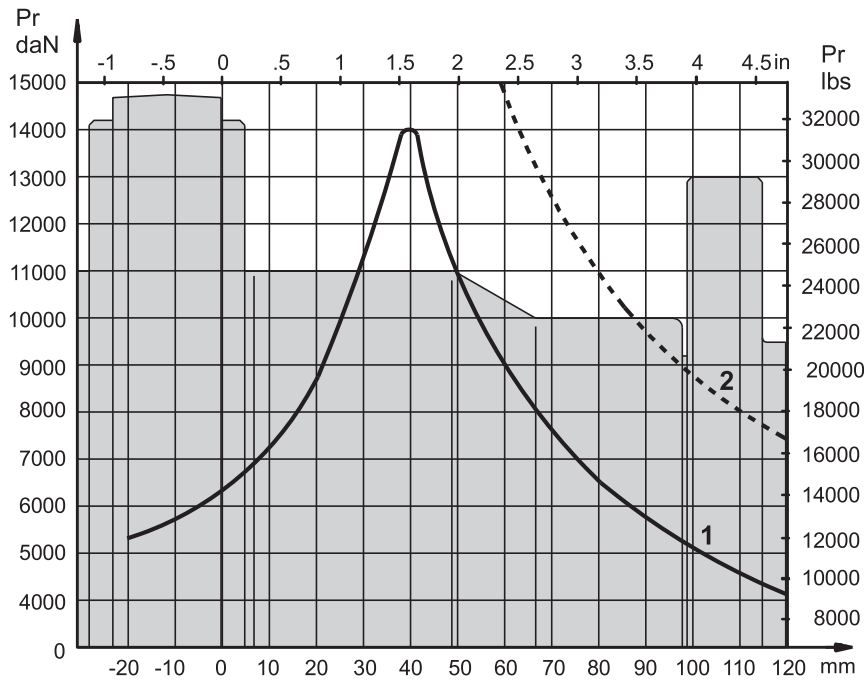

- 1 - Bearing curve: The curve applies to a B10 bearing life of 2000 hours at 100 RPM.
- 2 - Shaft curve: The curve represents Max. permissible radial shaft load with safety factor 2:1.

**ORDER CODE**

	1	2	3	4
<b>VMF</b>			<b>HD</b>	

**Pos.1 - Displacement code**

<b>315</b>	- 314,5 cm <sup>3</sup> /rev [19.18 in <sup>3</sup> /rev]
<b>400</b>	- 400,9 cm <sup>3</sup> /rev [24.45 in <sup>3</sup> /rev]
<b>500</b>	- 499,6 cm <sup>3</sup> /rev [30.48 in <sup>3</sup> /rev]
<b>630</b>	- 629,1 cm <sup>3</sup> /rev [38.38 in <sup>3</sup> /rev]
<b>800</b>	- 801,8 cm <sup>3</sup> /rev [48.91 in <sup>3</sup> /rev]

**Pos.2 - Ports**

<b>2</b>	- side ports, 2xG1, G <sup>1</sup> / <sub>4</sub> , BSP thread, ISO 228
<b>4</b>	- side ports, 2x1 <sup>1</sup> / <sub>16</sub> -12 UN, O-ring, <sup>1</sup> / <sub>16</sub> -18 UNF

**Pos.3 - Special Features**

<b>HD</b>	- Reinforced motor HD*
-----------	------------------------

For Other **Special Features** [see page 48](#)

**Pos.4 - Design Series**

omit - Factory specified

\* Drain line should always be used.  
The hydraulic motors are mangano-phosphatized as standard.